

COVER

Schematics Index^o

- 01 COVER
- 02 BLOCK
- 03 GPIO ASSIGNMENT
- 04 POWER TREE
- 05 CPU1
- 06 CPU2
- 07 DDR3 16bit x 2pcs
- 08 BESIDE CPU
- 09 POWER
- 10 NAND+eMMC+Nor
- 11 SOCKET
- 12 KEY-IR-JTAG-UART-SD
- 13 HDMI-SATA
- 14 WIFI_BT
- 15 AUDIO-AV
- 16 EMC

REVISION HISTORY

Rev	Description	Date	Drawn	Checked	Approved
A20_pcdiino_V1.0		2013-04-05	CWL		

LINKSPRITE			
A20_pcdiino_V1.0			
DSN	Maple	CHKD	
STAD		APPD	
DATE: 2014-04-05		SHEET	1 OF 16

BLOCK

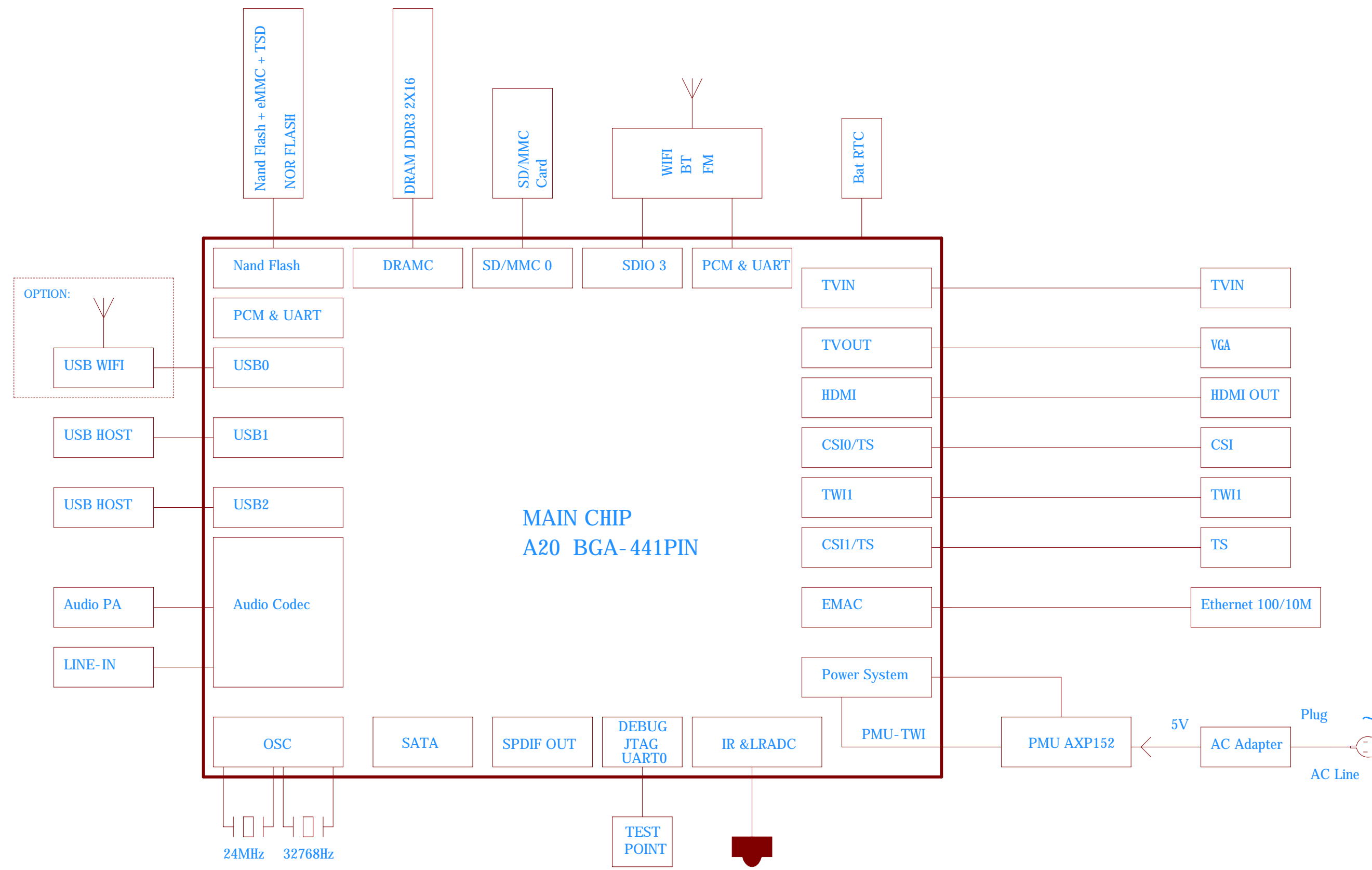

LINKSPRITE		
A20_pcduino_V1.0		
DSN	Maple	CHKD
STAD		APPD
DATE: 2014-04-05	SHEET	2 OF 16

GPIO ASSIGNMENT

Pin Group	Pin Name	Define	Function	Pin Group	Pin Name	Define	Function	Pin Group	Pin Name	Define	Function	Pin Group	Pin Name	Define	Function	Pin Group	Pin Name	Define	Function		
PA(18)	PA0	ERXD3	EMAC/GMAC	PC(25)	PC0	NWE#/Nor	NAND	PD(28)	PD18	LCD0_D18	VGA	PH(28)	PH0	GPIO	WIFI-SIMW	PI(22)	PI15	BT-HOST-WAKE	BT UART		
	PA1	ERXD2			PC1	NALE /Nor			PD19	LCD0_D19			PH1	GPIO	USB-ICTRL		PI16	UART2_RTS			
	PA2	ERXD1			PC2	NCLE /Nor			PD20	LCD0_D20			PH2	GPIO	USB0-DRV		PI17	UART2_CTS			
	PA3	ERXD0			PC3	NCE1			PD21	LCD0_D21			PH3	GPIO	USB0-IDDET		PI18	UART2_TX			
	PA4	ETXD3			PC4	NCE0			PD22	LCD0_D22			PH4	GPIO	SD0-DET		PI19	UART2_RX			
	PA5	ETXD2			PC5	NRE#			PD23	LCD0_D23			PH5	GPIO	RECOVERY		PI20	GPIO_OUT		BT-WAKE	
	PA6	ETXD1			PC6	NRB0			PD24	LCD0_CLK			PH6	GPIO	VGA-DET		PI21	GPIO_OUT		HP-DET	
	PA7	ETXD0			PC7	NRB1			PD25	LCD0_DE			PH7	GPIO	WIFI-HOST-WAKE						
	PA8	ERXCK			PC8	NDQ0			PD26	LCD0_HSYNC			PH8	GPIO	USB0-VBUSDET						
	PA9	ERXERR			PC9	NDQ1			PD27	LCD0_VSYNC			PH9	GPIO							
	PA10	ERXDV			PC10	NDQ2			PE0	CSI0_PCLK			CSI	PH10	GPIO						
	PA11	EMDC			PC11	NDQ3			PE1	CSI0_MCLK				PH11	GPIO						
	PA12	EMDIO			PC12	NDQ4		PE2	CSI0_HSYNC	PH12	GPIO										
	PA13	ETXFEN			PC13	NDQ5		PE3	CSI0_VSYNC	PH13	GPIO										
	PA14	ETXCK			PC14	NDQ6		PE4	CSI0_D0	PH14	GPIO			HDD-PWR-EN							
	PA15	ECRS			PC15	NDQ7		PE5	CSI0_D1	PH15	GPIO			BT-HOST-WAKE							
	PA16	ECOL			PC16	NWP		PE6	CSI0_D2	PH16	GPIO			STATUS-LED							
PA17	ETXERR	PC17	NCE2		PE7	CSI0_D3		PH17	GPIO	PWR-LED											
PB(24)	PB0	TWI0_SCK	PMU		PC18	NCE3		PF(6)	PE8	CSI0_D4	PH(28)			PH18	GPIO						
	PB1	TWI0_SDA			PC19	SPI2_CS			PE9	CSI0_D5				PH19	GPIO	LCD-BL-EN					
	PB2	PWM0			PC20	SPI2_SCLK			PE10	CSI0_D6				PH20	GPIO	LCD-PWR					
	PB3	GPIO_OUT			MUTE	PC21			SPI2_MOSI	PE11				CSI0_D7	PH21	GPIO	CAM-R-RESE				
	PB4	IR0_RX	IR-A20		PC22	GPIO_OUT			PE0	SDC0_D1			SDC0	PH22	GPIO	CAM-F-RESET#					
	PB5	I2S_MCLK	BT-REST		PC23				PE1	SDC0_D0				PH23	GPIO	CAM-PWR-EN					
	PB6	I2S_BCLK	BT-PCM-CLK		PC24	NDQS			PE2	SDC0_CLK				PH24	GPIO	CAM-R-STBY-EN					
	PB7	I2S_LRCK	BT-PCM-SYNC	PD0	LCD0_D0	PE3	SDC0_CMD		PH25	GPIO				CAM-F-STBY-EN							
	PB8	I2S_DO0	BT-PCM-OUT	PD1	LCD0-D1	PE4	SDC0_D3		PH26	GPIO				LCD1-HSYNC							
	PB9	GPIO	USB0-DRV	PD2	LCD0-D2	PF5	SDC0_D2		PH27	GPIO				LCD1-VSYNC							
	PB10	GPIO	I2S_D02	PD3	LCD0-D3	PG(12)	PG0		CSI1_PCLK	TS		PI(22)	PI0		WIFI SDIO						
	PB11	GPIO	I2S_D03	PD4	LCD0-D4		PG1		CSI1_MCLK				PI1								
	PB12	GPIO	BT-PCM-IN/I2S DI	PD5	LCD0-D5		PG2	CSI1_HSYNC	PI2												
	PB13	GPIO	SPDIF-DO/TP-WAKEUP	PD6	LCD0-D6		PG3	CSI1_VSYNC	PI3				PWM								
	PB14	JTAG_MS0	JTAG/SPI2	PD7	LCD0-D7		PG4	CSI1_D0	PI4				SDC3_CMD								
	PB15	JTAG_CK0		PD8	LCD0-D8		PG5	CSI1_D1	PI5				SDC3_CLK								
	PB16	JTAG_DO0		PD9	LCD0-D9		PG6	CSI1_D2	PI6				SDC3_D0								
	PB17	JTAG_DI0		PD10	LCD0-D10		PG7	CSI1_D3	PI7				SDC3_D1								
	PB18	TWI1_SCK	TWI1	PD11	LCD0-D11		PG8	CSI1_D4	PI8				SDC3_D2								
	PB19	TWI1_SDA	TWI1	PD12	LCD0-D12		PG9	CSI1_D5	PI9				SDC3_D3								
	PB20	TWI2_SCK	TWI2	PD13	LCD0-D13		PG10	CSI1_D6	PI10				SPI0_CS0								
	PB21	TWI2_SDA	TWI2	PD14	LCD0-D14		PG11	CSI1_D7	PI11				GPIO	SPI0_CLK							
	PB22	UART0_TX	UART(DEBUG)	PD15	LCD0-D15			PI12	SPI0_MOSI				CLK-32K								
	PB23	UART0_RX		PD16	LCD0-D16			PI13	HCEC				HDMI_CEC								
			PD17	LCD0-D17			PI14	WIFI-HOST-WAKE	WIFI												

LINKSPRITE		
A20_pcduino_V1.0		
DSN	Maple	CHKD
STAD		APPD
DATE: 2014-04-05		SHEET 3 OF 16

POWER TREE

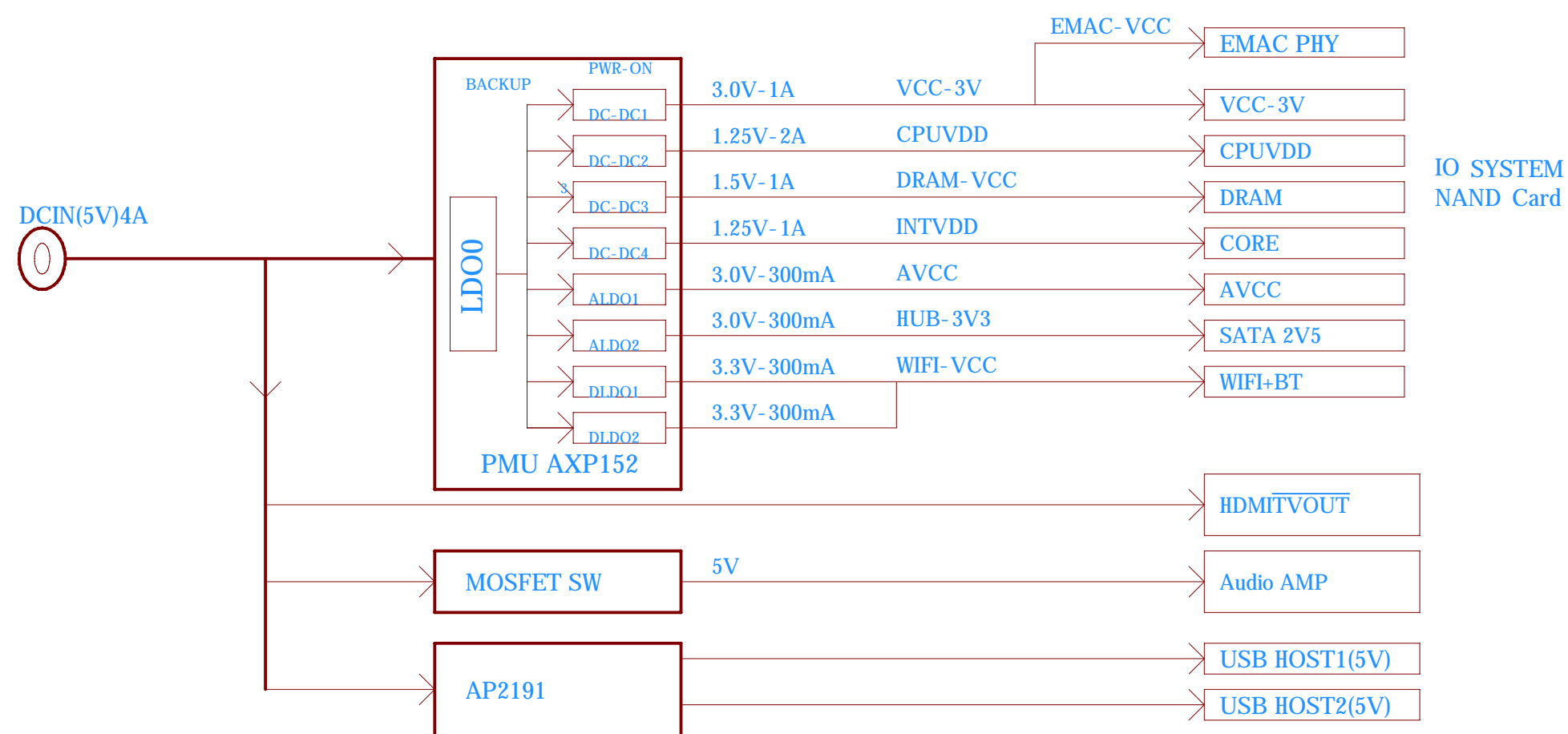

LINKSPRITE		
A20_pcduino_V1.0		
DSN	Maple	CHKD
STAD		APPD
DATE: 2014-04-05	SHEET	4 OF 16

CPU1

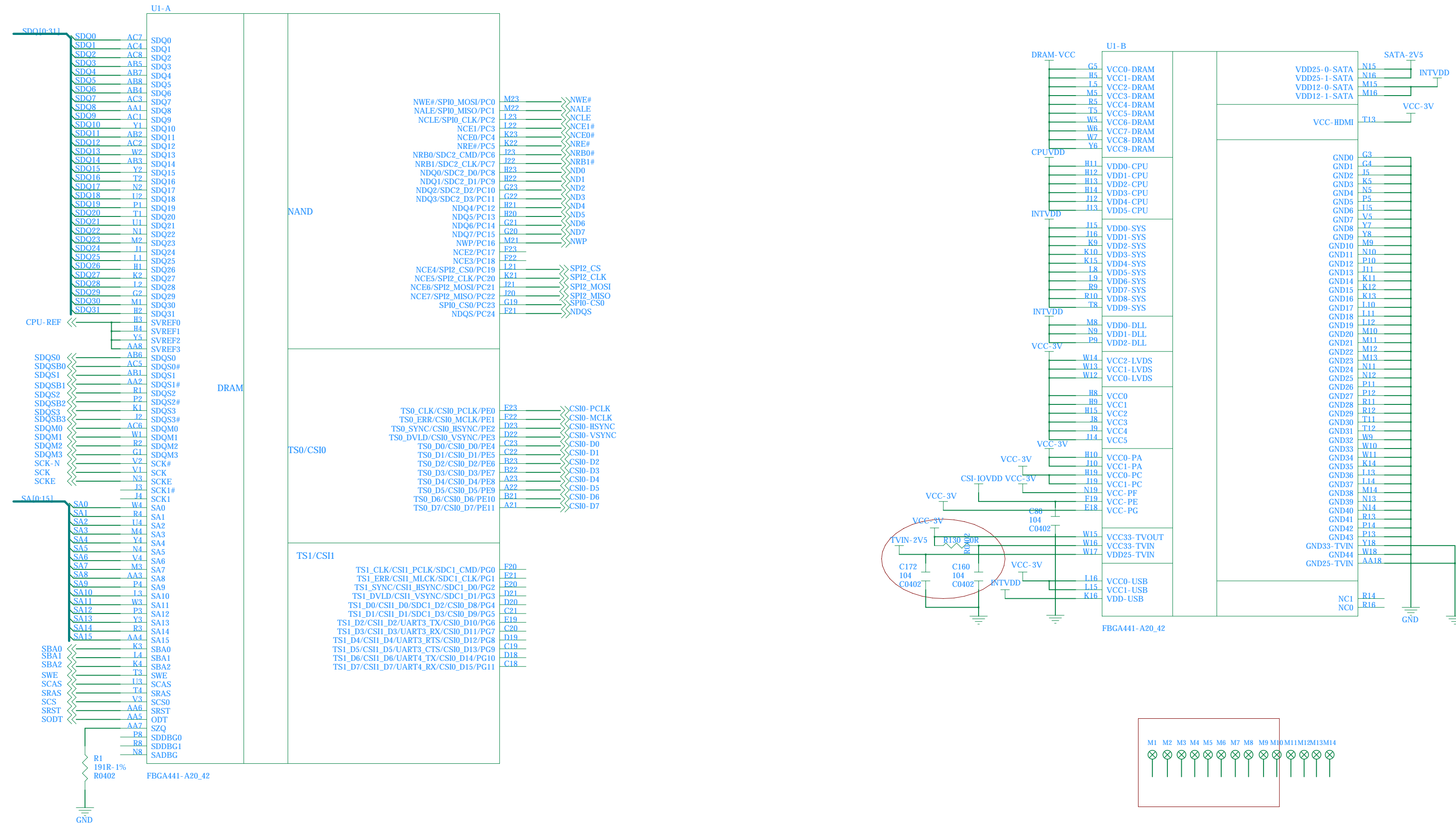

LINKSPRITE		
A20_pcduno_V1.0		
DSN	Maple	CHKD
STAD		APPD
DATE: 2014-04-05		SHEET 5 OF 16

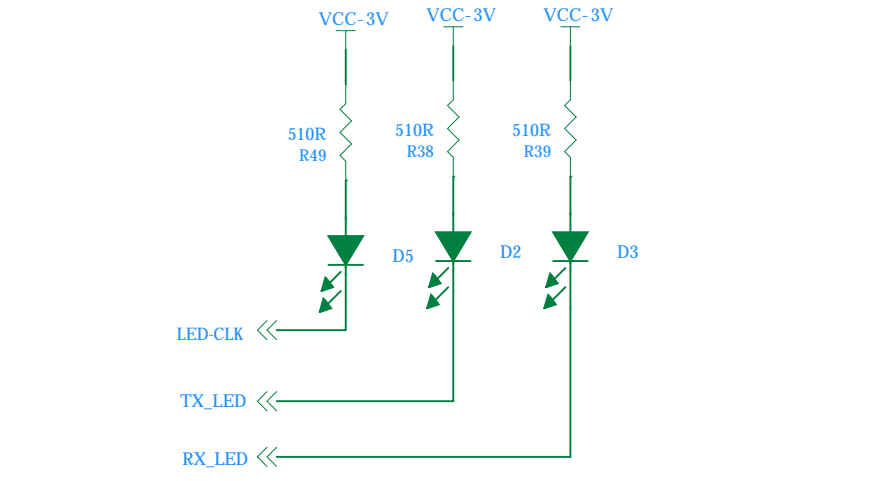
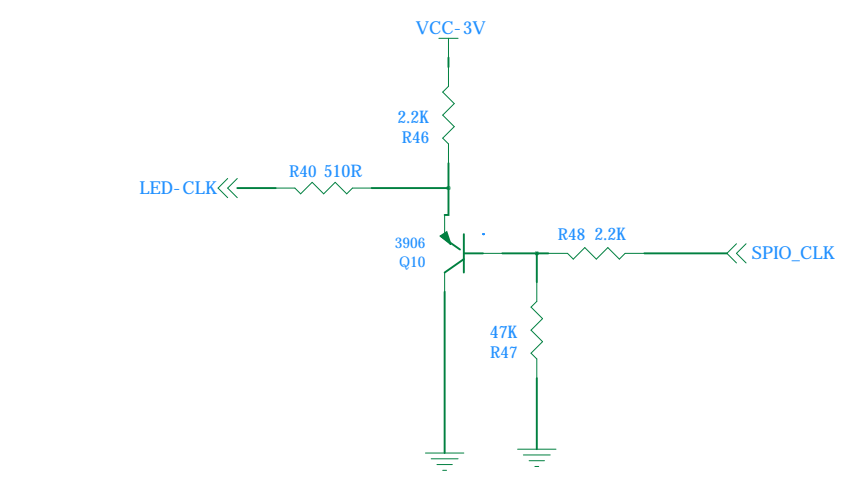
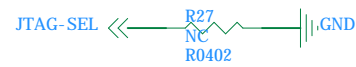
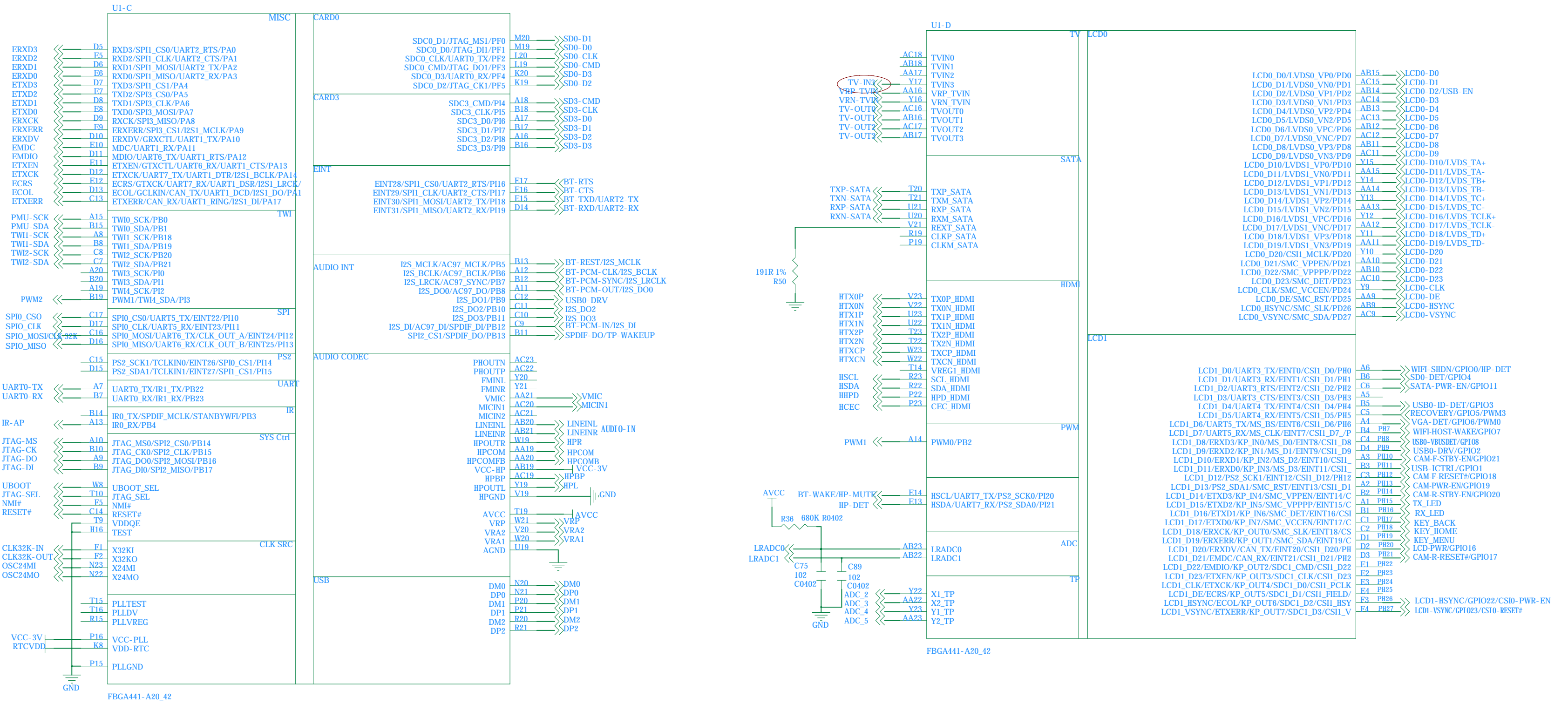

LINKSPRITE		
A20_pcdduino_V1.0		
DSN	Maple	CHKD
STAD		APPD
DATE: 2014-04-05		SHEET 6 OF 16

DDR3- 16BITX2

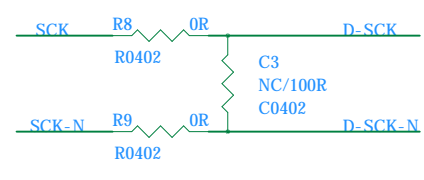
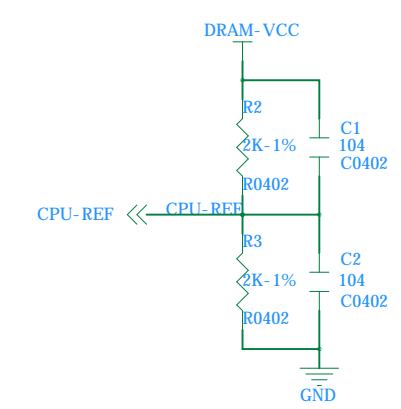
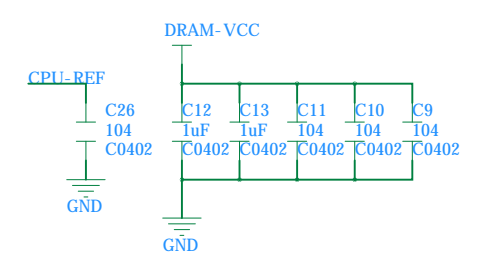
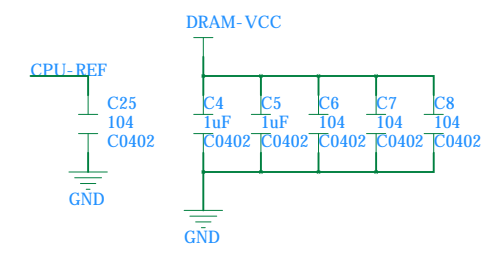
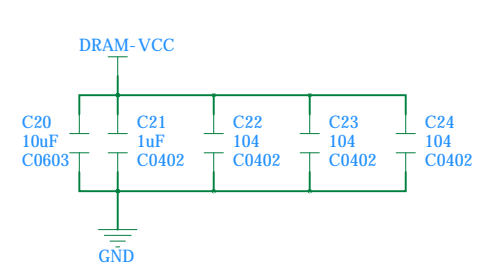
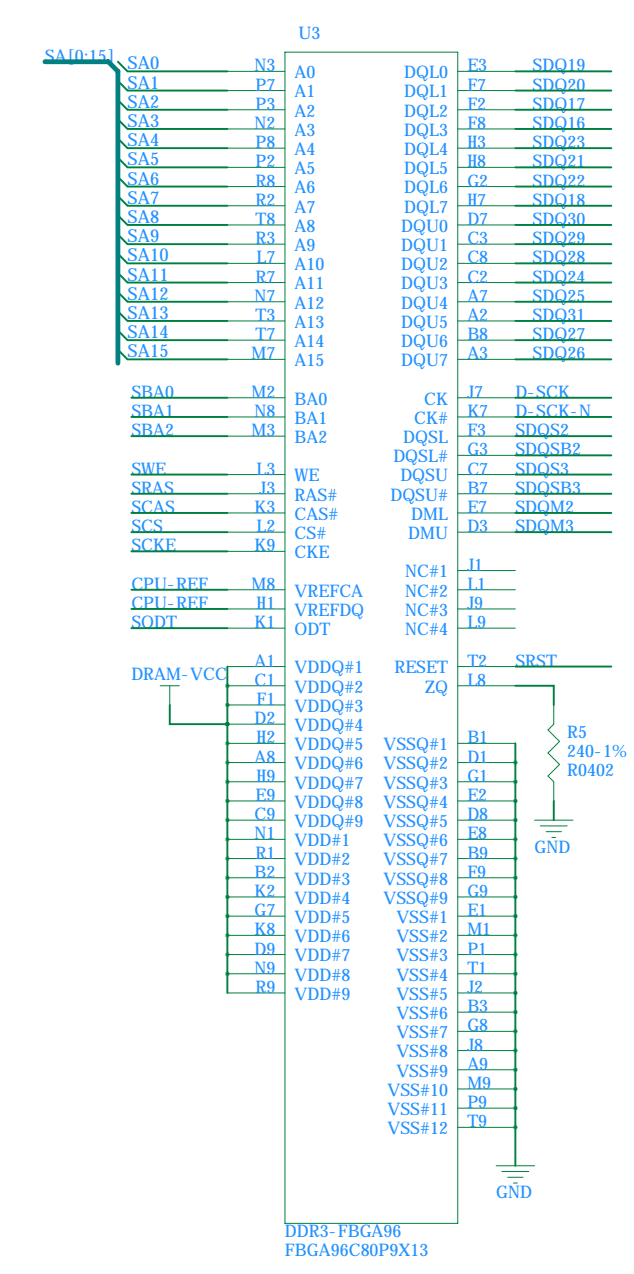
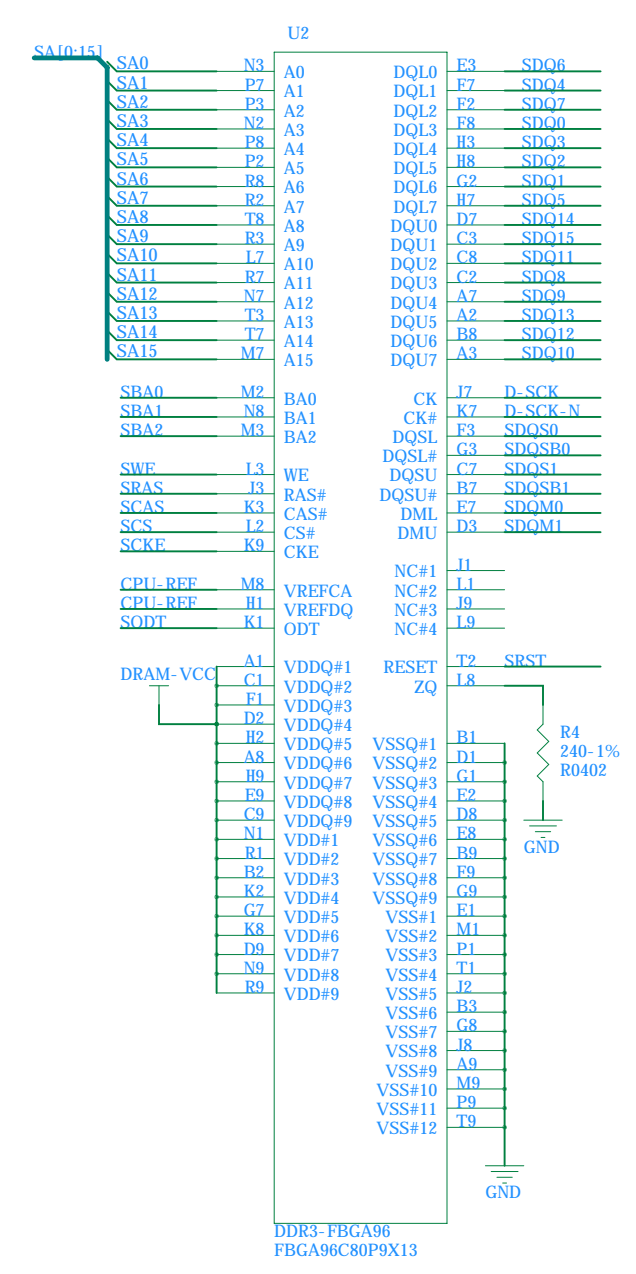
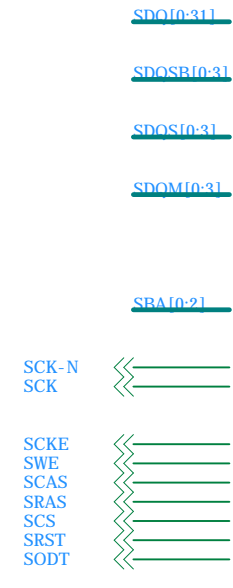

LINKSPRITE	
A20_pcdduino_V1.0	
DSN	Maple
STAD	CHKD
DATE: 2014-04-05	APPD
SHEET	7 OF 16

BESIDE CPU

The device cannot be modified or deleted, otherwise cause system instability!

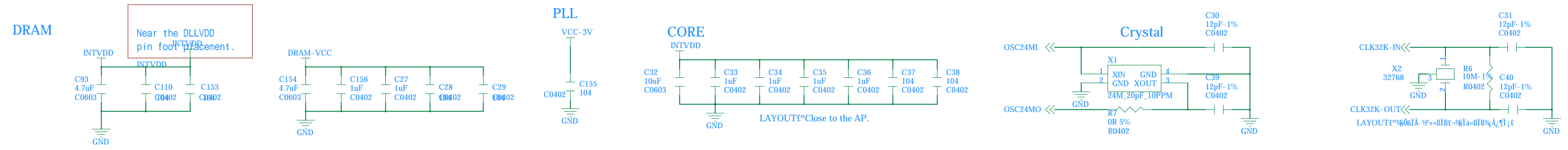

AUDIO&SYS

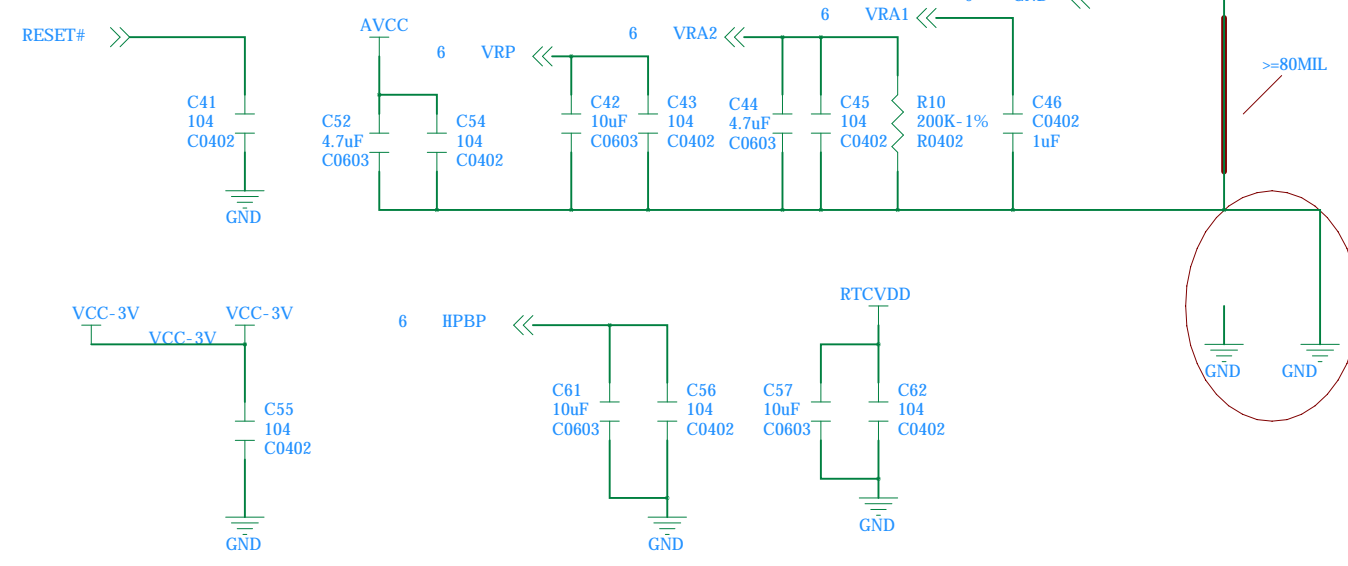

USB

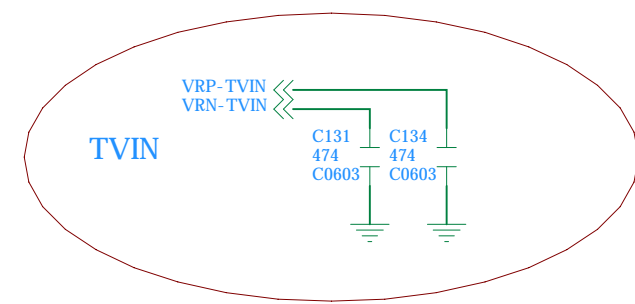
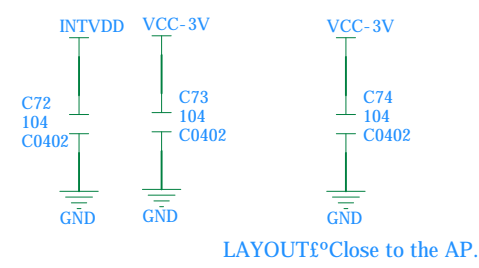

CPU&TV

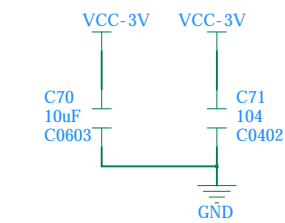
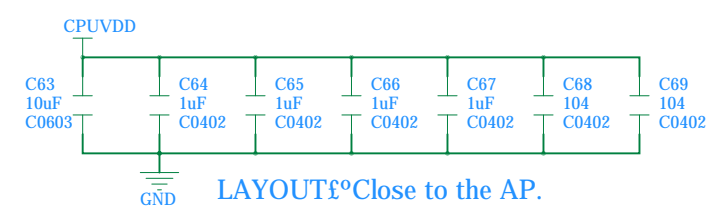

TWI-PULLUP

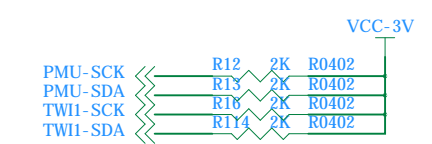

LINKSPRITE

A20_pcduino_V1.0

DSN Maple CHKD

STAD APPD

DATE: 2014-04-05

SHEET 8 OF 16

DC-IN-5V

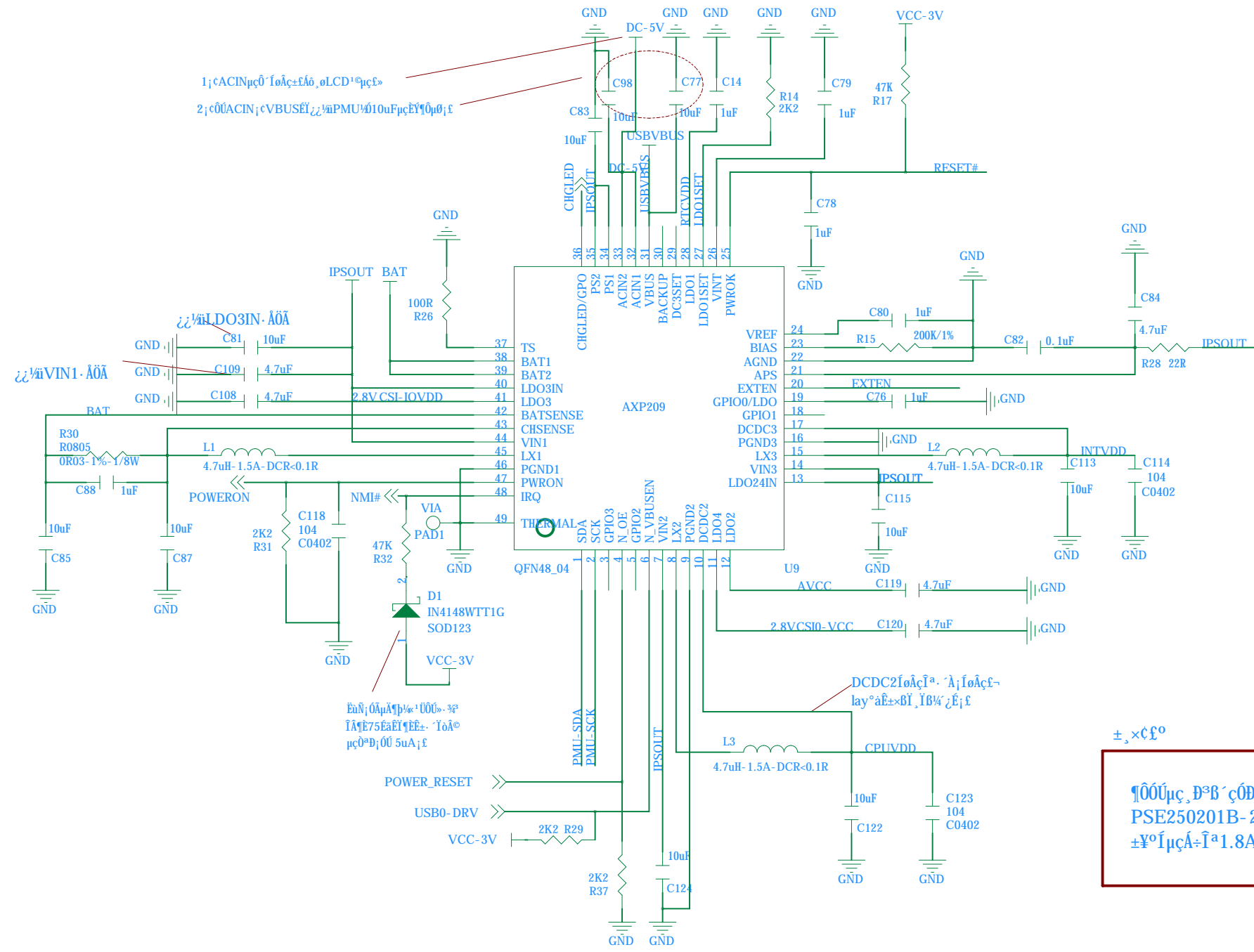
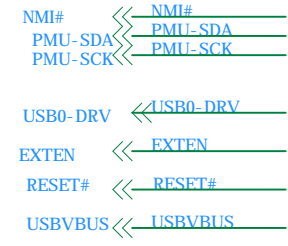

POWER LINE:Width>=80mil



POWER LINE:Width>=40mil

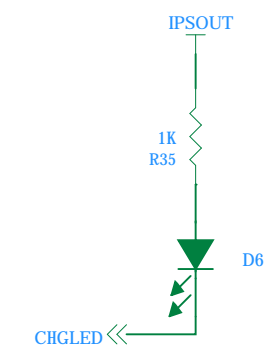
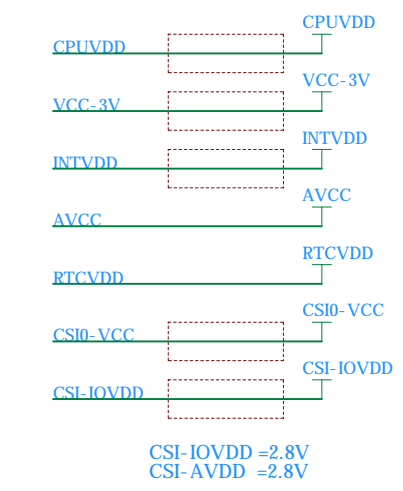

±, xCf°
 100µC, D°B · c0DCá± j0°Ç0µÁf~f.Æ0E'0ÁÇ-Á=µÁ
 PSE250201B-2R2MS, Æ1á»yÍ°2.6x2.1Æ½ ½°ÁÁ×f~
 ±Y°ÍµÇÁ=Í°1.8A, 0±Á±×è; 'Í°85°ÁÁ· jf.

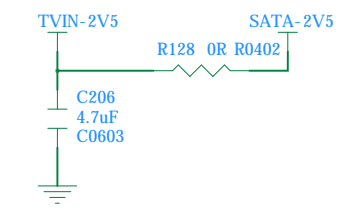
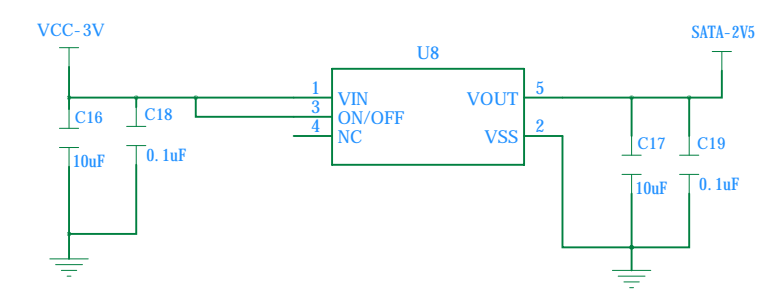
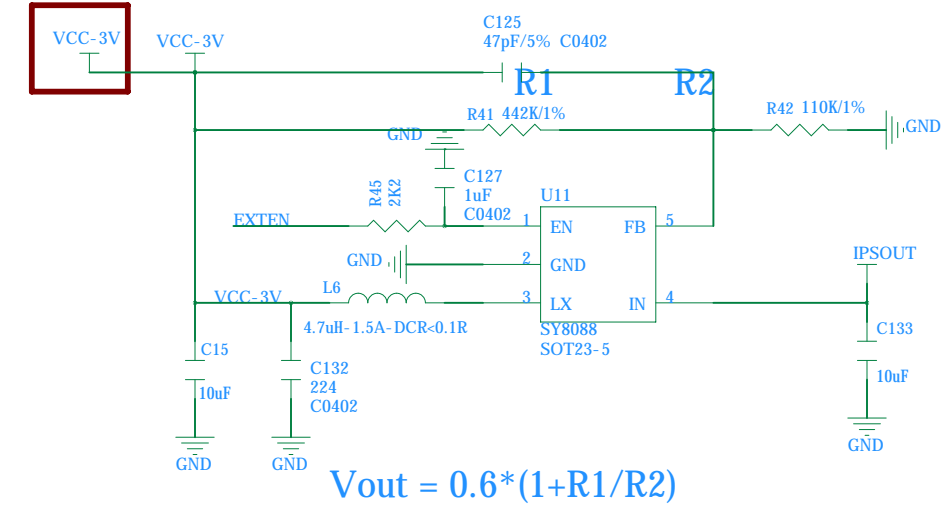
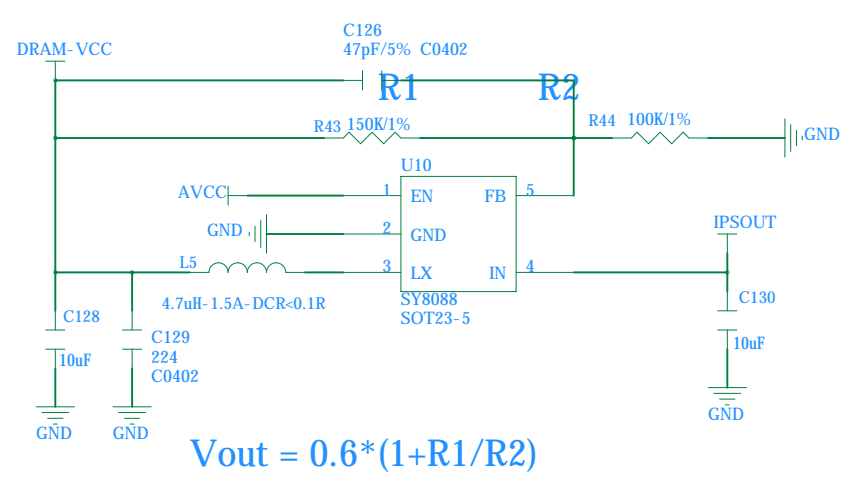

LINKSPRITE		
A20_pcduino_V1.0		
DSN	Maple	CHKD
STAD		APPD
DATE: 2014-04-05	SHEET	9 OF 16

NAND

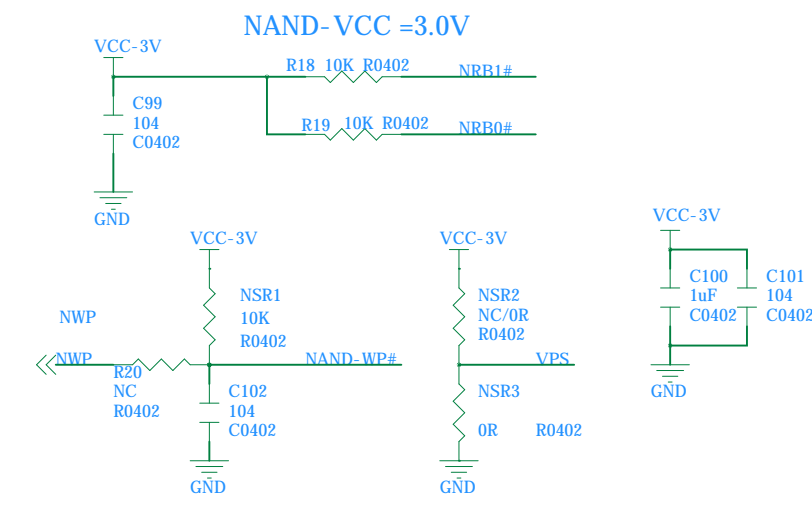
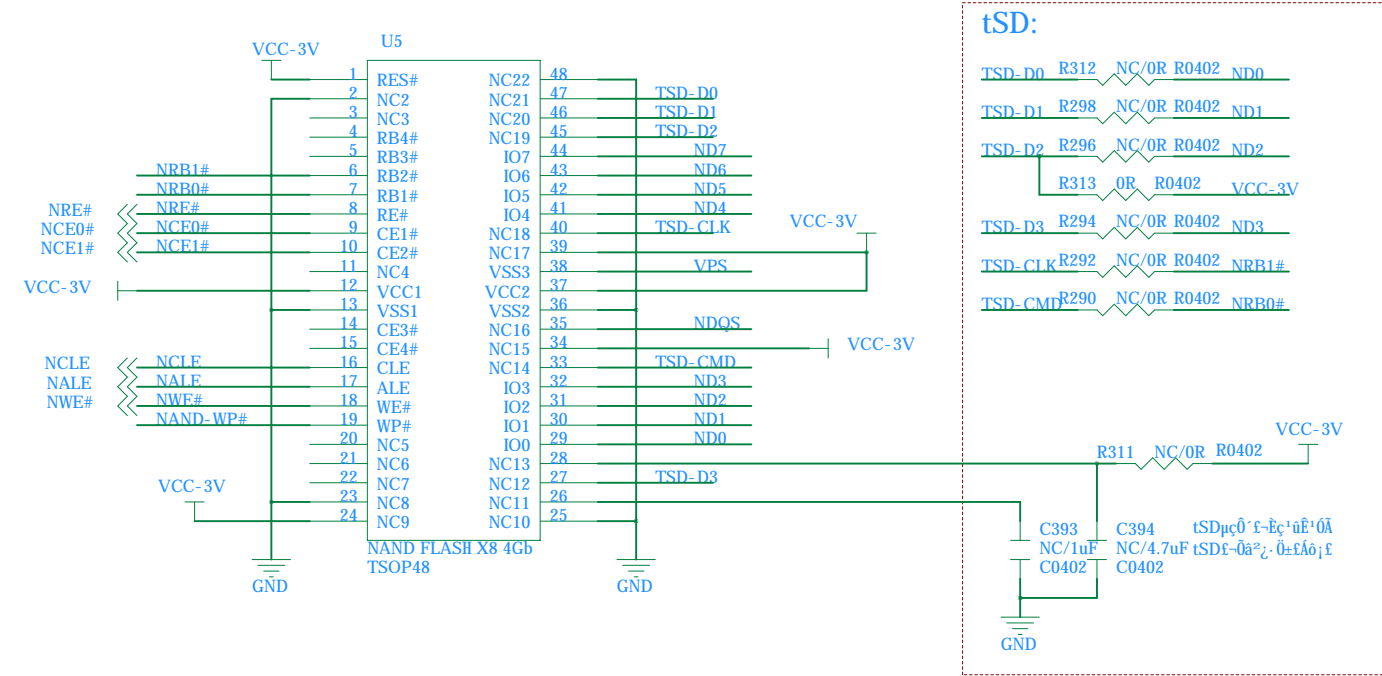
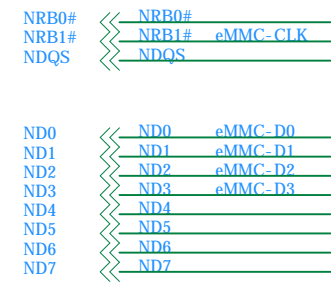

If paste Intel|Toshiba|Samsung 2xnm TSOP Nand:-
NSR2=OR|NSR3=NC|Other NSR2=NC|NSR3=OR.

eMMC

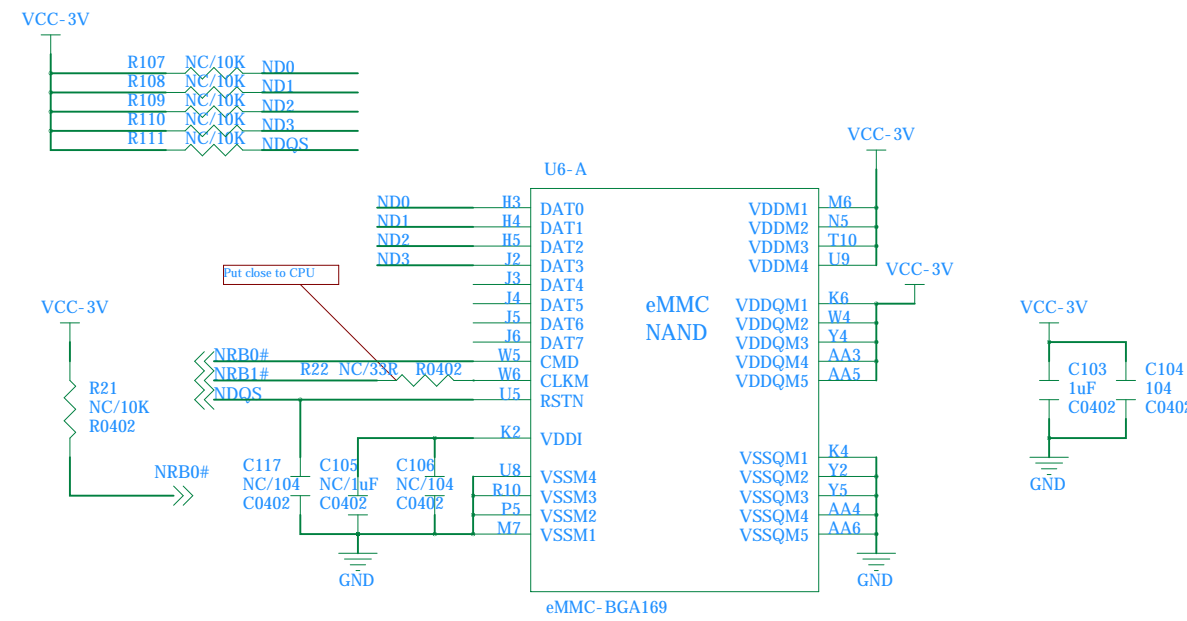

Note layout :Put the eMMC in TSOP48, producing two choose one..

Nor



LINKSPRITE		
A20_pcduno_V1.0		
DSN	Maple	CHKD
STAD		APPD
DATE: 2014-04-05		SHEET 10 OF 16

SOCKET

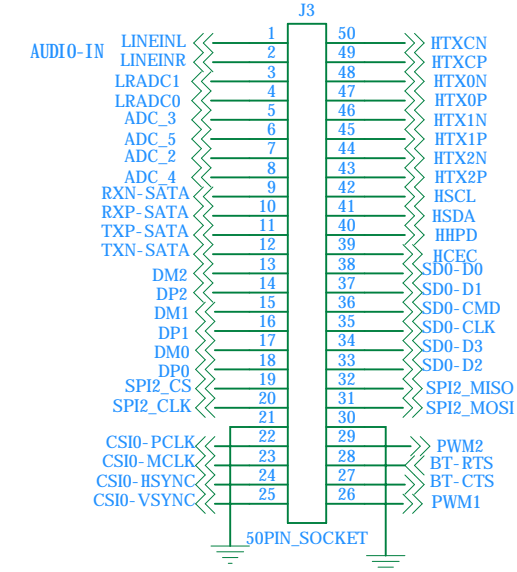
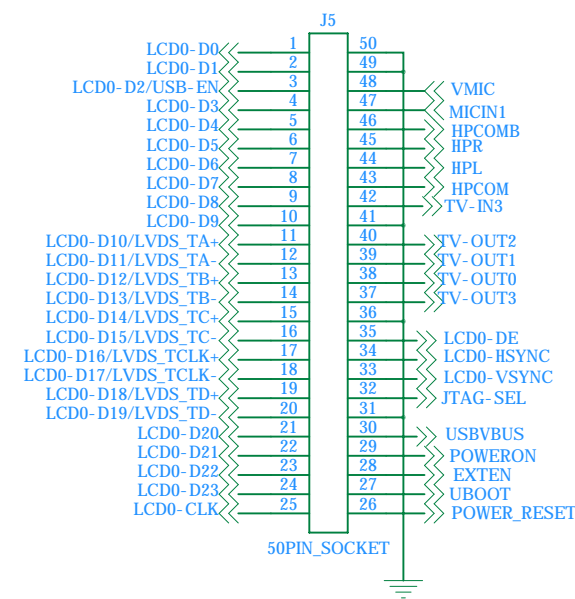
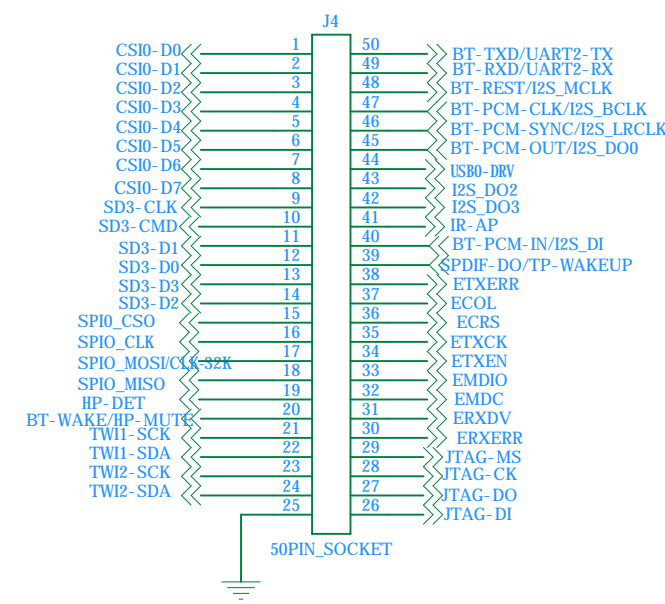
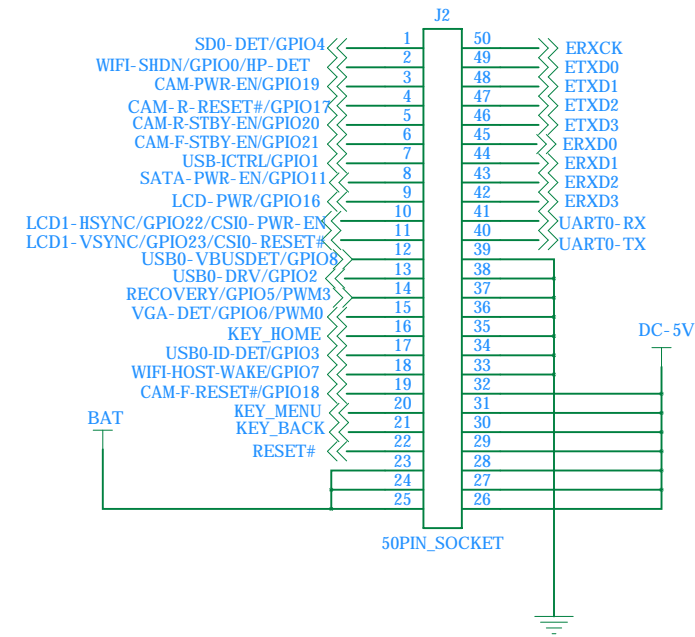

3yÄeÄaDÄ°ÄEaEeEa°ö¿Úíaf~PHY ¼¿Úf~x"ÖÄµ±EÖ¼¿Ú É-HDMI¼¿Úf~ÄaÖa¼E¿Ü¼¿ÉÄÜE±µ±Äa°EGPIO

LINKSPRITE		
A20_pcdduino_V1.0		
DSN	Maple	CHKD
STAD		APPD
DATE: 2014-04-05	SHEET	11 OF 16